

Option

SDI-12

Configuration and consultation
for Agrónic 2500, Agrónic 4500
and Agrónic 5500

ÍNDICE

1.	DESCRIPTION.....	2
1.1.	DEVICE CONFIGURATION.....	2
1.1.1.	5TE DECAGON MODEL CONFIGURATION.....	3
1.1.2.	GS3 DECAGON MODEL CONFIGURATION.....	3
1.1.3.	AQUACHECK-4 MODEL CONFIGURATION.....	4
1.1.4.	AQUACHECK-8 MODEL CONFIGURATION.....	4
1.1.5.	METER GROUP TEROS-12 MODEL CONFIGURATION.....	5
1.1.6.	SENTEK DRILL&DROP MODEL CONFIGURATION.....	6
1.1.7.	MODEL CONFIGURATION RK900-12.....	7
1.1.8.	MODEL CONFIGURATION EC-TEMP H2O.....	9
1.3.	ASSIGN ADDRESS.....	10
1.2.	INPUTS AND OUTPUTS ASSIGNMENT.....	10
2.	CONSULTATION.....	11
2.1.	COMMUNICATION CONSULT ON THE CONTROLLERS.....	11
3.	CONNECTING.....	12
3.1.	WIRING ON AGRÓNIC 4500.....	14

1. Description

The Agrónic 2500, the Agrónic 4500 and the Agrónic 5500 have an SDI-12 bus where you can connect devices that use this type of communication.

The bus is made up of 3 wires (+12Vdc, GND, and data) where up to 8 devices can be connected at to maximum distance of 50 metres. Each device can have multiple sensors. The maximum current must not exceed 500 mA.

In order to use the SDI-12 bus in an Agrónic 4500 and Agrónic 5500, the controller must have the SDI-12 option activated. In an Agrónic 2500, in addition to having the SDI-12 option activated, the controller must have the Plus version.

The system configuration can be accessed through “Parameters – Installer - Communications - SDI-12.”

All of the operating parameters of the sensors that are connected to the Agrónic can be configured in “Device.”

INSTALLER SDI-12

1. Device
2. Assign address

In “Assign address,” you can configure the address of each of the devices. The parameters in this section should only be changed if instructed by the Progrés technical personnel.

1.1. DEVICE CONFIGURATION

The Agrónic allows you to connect up to 8 devices.

Device: number of the device to be configured.

From 1 to 8.

Model: there are different models, each with to specific function.

SDI-12

Device: 1

Model: 5TE Decagon

Model	Function
“5TE Decagon”	Reading of moisture, conductivity, and soil temperature.
“GS3 Decagon”	Reading of moisture, conductivity, and soil temperature.
“AquaCheck-4”	Reading of moisture and soil temperature at 4 different levels.
“AquaCheck-8”	Reading of moisture and soil temperature at 8 different levels.
“Meter Group Teros-12”	Reading of moisture, conductivity, and soil temperature.
“Sentek Drill&Drop”	Reading of moisture, conductivity, and temperature of the ground in 6 different levels.
“RK900-12”	Weather station for reading the Vane, Anemometer, Temperature, Relative Humidity, Atmospheric Pressure, Solar Radiation, Wet Bulb and Vapor Pressure Deficit.
“EC- Temp H2O”	Electrical conductivity and water temperature reading

Take care to ensure that the device number and model match the one connected to the Agrónic.

1.1.1. STE DECAGON MODEL CONFIGURATION

Device for reading the soil's volumetric water content (VWC), temperature, and EC (electrical conductivity).

Soil type of soil.
[Mineral], [Mulch], [Rock wool], [Perlite].

SDI-12 1
Soil: Mineral
Format: 0
Density: 0.00

Format data type sent by the sensor. From 0 to 3. Default 0.

- “0”: agronomic. VWC[%], EC_pore water [mS/cm], Temp[°C]
- “1”: raw values. ϵ , EC_bulk [mS/cm], Temp [°C]
- “2”: EC saturation. VWC[%], EC_saturation [mS/cm], Temp[°C]

Density apparent density of the medium. From 0 to 2.65. Default 0. Only used if the format is “2.”

Sensors (analogue inputs)

No.	Description	Units	
01	Sensor: soil moisture	from 000,0 to 100,0	%
02	Sensor: soil EC	from 00,00 to 23,00	mS/cm
03	Sensor: soil temperature	from -40,0 to +50,0	°C

1.1.2. GS3 DECAGON MODEL CONFIGURATION

Device for reading volumetric water content in the soil (VWC), temperature, and EC (electrical conductivity).

Soil type of soil.
[Mineral], [Rock wool], [Peat], [Coconut fibre].

SDI-12 1
Soil: Mineral
Format: 0
Density: 0.00

Format type of data that the sensor sends. From 0 to 3. Default 0.

- “0”: agronomic. VWC[%], EC_pore water [mS/cm], Temp[°C]
- “1”: raw values. ϵ , EC_bulk [mS/cm], Temp [°C]
- “2”: EC saturation. VWC[%], EC_saturation [mS/cm], Temp[°C]

Density apparent density of the medium. From 0 to 2.65. Default 0. Only used if the format is “2.”

Sensors (analogue inputs)

No.	Description	Units	
01	Sensor: soil moisture	from 000,0 to 100,0	%
02	Sensor: soil EC	from 00,00 to 23,00	mS/cm
03	Sensor: soil temperature	from -40,0 to +50,0	°C

1.1.3. AQUACHECK-4 MODEL CONFIGURATION

Device for reading the soil's volumetric water content (VWC), and temperature in 4 distinct depth levels. Level 1 indicates the shallowest depth.

SDI-12 1
Soil: Mineral

Soil type of soil.

[Mineral], [Sandy], [Clay], [Sandy-loam], [Loam], [Clay-loam]

Sensors (analogue inputs)

No.	Description	Units	
01	Level 1: soil moisture.	from 000,0 to 100,0	%
02	Level 1: soil temperature.	from -40,0 to +50,0	°C
03	Level 2: soil moisture.	from 000,0 to 100,0	%
04	Level 2: soil temperature.	from -40,0 to +50,0	°C
05	Level 3: soil moisture.	from 000,0 to 100,0	%
06	Level 3: soil temperature.	from -40,0 to +50,0	°C
07	Level 4: soil moisture.	from 000,0 to 100,0	%
08	Level 4: soil temperature.	from -40,0 to +50,0	°C

1.1.4. AQUACHECK-8 MODEL CONFIGURATION

Device for reading the soil's volumetric water content (VWC), and temperature in 8 distinct depth levels. Level 1 indicates the shallowest depth.

SDI-12 1
Soil: Mineral

Soil type of soil.

[Mineral], [Sandy], [Clay], [Sandy-loam], [Loam], [Clay-loam]

Sensors (analogue inputs)

No.	Description	Units	
01	Level 1: soil moisture.	from 000,0 to 100,0	%
02	Level 1: soil temperature.	from -40,0 to +50,0	°C
03	Level 2: soil moisture.	from 000,0 to 100,0	%
04	Level 2: soil temperature.	from -40,0 to +50,0	°C
05	Level 3: soil moisture.	from 000,0 to 100,0	%
06	Level 3: soil temperature.	from -40,0 to +50,0	°C
07	Level 4: soil moisture.	from 000,0 to 100,0	%
08	Level 4: soil temperature.	from -40,0 to +50,0	°C
09	Level 5: soil moisture.	from 000,0 to 100,0	%
10	Level 5: soil temperature.	from -40,0 to +50,0	°C
11	Level 6: soil moisture.	from 000,0 to 100,0	%
12	Level 6: soil temperature.	from -40,0 to +50,0	°C
13	Level 7: soil moisture.	from 000,0 to 100,0	%
14	Level 7: soil temperature.	from -40,0 to +50,0	°C
15	Level 8: soil moisture.	from 000,0 to 100,0	%
16	Level 8: soil temperature.	from -40,0 to +50,0	°C

1.1.5. METER GROUP TEROS-12 MODEL CONFIGURATION

Device for reading volumetric water content in the soil (VWC), temperature, and EC (electrical conductivity).

Soil type of soil.

[Mineral], [Rock wool], [Peat], [Coconut fibre]. Only Mineral and Peat are valid.

SDI-12 1
Soil: Mineral
Format: 0
Density: 0.00

Format Data type sent by the sensor. From 0 to 3. Default 0.

- “0”: agronomic: VWC[%], EC_pore water [mS/cm], Temp[°C]
- “1”: raw values: ε, EC_bulk [mS/cm], Temp [°C]
- “2”: agronomic: VWC[%], EC_saturation [mS/cm], Temp[°C]

Density apparent density of the medium. From 0 to 2.65. Default 0. Only used if the format is “2.”

Sensors (analogue inputs)

No.	Description	Units	
01	Sensor: soil moisture Formats 0 y 2.	from 000,0 to 100,0	%
01	Sensor: raw value ε. Format 1.	from 01.0 to 80.0	
02	Sensor: soil EC	from 00,00 to 23,00	mS/cm
03	Sensor: soil temperature	from -40,0 to +60,0	°C

1.1.6. SENTEK DRILL&DROP MODEL CONFIGURATION

Device for reading the soil's volumetric water content (VWC), temperature, and conductivity (VIC: Volumetric Ion Content, provides trends in the conductivity value, but not its absolute value). Level 1 indicates the shallowest depth.

This device does not have configuration parameters.

SDI-12 1
Soil: Mineral

<i>Sensors (analogue inputs)</i>			
No.	Description	Units	
01	Level 1: soil moisture (VWC)	from 000,0 to 100,0	%
02	Level 1: conductividad del suelo (VIC)	from 0 to 10000	
03	Level 1: soil temperature.	from -20,0 to +60,0	°C
04	Level 2: soil moisture (VWC)	from 000,0 to 100,0	%
05	Level 2: conductividad del suelo (VIC)	from 0 to 10000	
06	Level 2: soil temperature.	from -20,0 to +60,0	°C
07	Level 3: soil moisture (VWC)	from 000,0 to 100,0	%
08	Level 3: conductividad del suelo (VIC)	from 0 to 10000	
09	Level 3: soil temperature.	from -20,0 to +60,0	°C
10	Level 4: soil moisture (VWC)	from 000,0 to 100,0	%
11	Level 4: conductividad del suelo (VIC)	from 0 to 10000	
12	Level 4: soil temperature.	from -20,0 to +60,0	°C
13	Level 5: soil moisture (VWC)	from 000,0 to 100,0	%
14	Level 5: conductividad del suelo (VIC)	from 0 to 10000	
15	Level 5: soil temperature.	from -20,0 to +60,0	°C
16	Level 6: soil moisture (VWC)	from 000,0 to 100,0	%
17	Level 6: conductividad del suelo (VIC)	from 0 to 10000	
18	Level 6: soil temperature.	from -20,0 to +60,0	°C

IMPORTANT

Optionally it is possible to configure the sensor to obtain an EC reading instead of VIC. This option is available:

- On the TriScan model when the serial number is greater than 13000.
- In sandy and sandy loam soils with low ion exchange capacity.

Set the parameters according to the following table:

<i>Drill&Drop sensor format</i>	
Parameter	<i>Optional</i>
	Value 2
	EC [dS/m]
N. of enters	1
N. of decimals	3
Sign	no
Units	dS/m
Calibration Point 1	
Real value	800 mV
Logical value	0,660 dS/m
Calibration Point 2	
Real value	4000 mV
Logical value	7,660 dS/m

1.1.7. MODEL CONFIGURATION RK900-12

Weather station for reading the Vane, Anemometer, Temperature, Relative Humidity, Atmospheric Pressure, Solar Radiation, Wet Bulb and Vapor Pressure Deficit.

This device has no configuration parameters.

SDI-12
Device: 1
Model: RK900-12

<i>Sensors (analog inputs)</i>		
Num.	Description	Rank and units
01	Veane	0 - 360 °
02	Anemometer	0 - 120 km/h
03	Temperature	-30 a -60 °C
04	Relative Humidity	0 a 100 %
05	Atmospheric pressure	150 a 1020 hPa
06	Solar radiation	0 a 2000 W/m ²
07	Wet bulb	-20.0 a +20.0 °C
08	Vapor Pressure Deficit	0.00 a 8.00 kPa

Set the parameters according to the following table:

<i>Weather Station Formats</i>						
Parameter	Value 1	Value 2	Value 3	Value 4	Value 5	Value 6
	Vane [°]	Anemo- meter [Km/h]	Temperature [°C]	Humidity [%]	Air pressure [hPa] ⁽¹⁾	Solar Radiation [W/m ²]
N. of enters	3	3	2	3	4	4
N. of decimals	0	0	1	0	0	0
Sign	No	No	Yes	No	No	No
Units	°	Km/h	°C	%	hPa	W/m ²
Calibration point 1						
Real value	800 mV	800 mV	800 mV	800 mV	800 mV	800 mV
Logic value	000 °	0 km/h	-30,0 °C	000 %	150 hPa	0 W/m ²
Calibration point 2						
Real value	4000 mV	4000 mV	4000 mV	4000 mV	4000 mV	4000 mV
Logic value	360 °	120 km/h	+60,0 °C	100 %	1020 hPa	2000 W/m ²

(1): When the AgroBee-L Meteo module is linked to an Agrónic 4500, the unit to be selected will be “mbar”(1 hPa = 1 mbar).

<i>Calculated Sensor Formats</i>		
Parameter	Valor 7	Valor 8
	Wet Bult [°C]	Vapor Deficit pressure [kPa]
N. of enters	2	1
N. of decimals	1	2
Sign	Yes	No
Units	°C	kPa
Calibration point 1		
Real value	800 mV	800 mV
Logic value	-20,0 °C	0,00 kPa
Calibration point 2		
Real value	4000 mV	4000 mV
Logic value	+20,0 °C	8,00 kPa

1.1.8. MODEL CONFIGURATION EC-TEMP H2O

Device for rading EC (Electrical Conductivity) and water temperature.

SDI-12 1

Sensors (analog inputs)

Núm.	Description	Units	
01	CE	de 000,0 a 100,0	mS/cm
02	Temperature	de -30,00 a 60,00	°C

1.3. ASSIGN ADDRESS

Each device that is connected to the SDI-12 bus must have a different address. The devices connected to the Agrónic must have addresses from 1 to 8, which corresponds to the device number.

SDI-12
Current address: 1
New address: 2

To configure the address, the device must be connected to the Agrónic SDI-12 bus.

Once the device is detected, it will tell us the address it has and the option to modify to a new address (1 to 8).

This operation must be performed with only one device connected.

IMPORTANT

When configuring in the Agrónic, only one device can be connected--the one that is being configured.

1.2. INPUTS AND OUTPUTS ASSIGNMENT

When an input or output of an SDI-12 device is assigned in any of the parameters of the Agrónic 2500 and Agrónic 5500, the first digit is always a '4,' the following two figures indicate the device number, and the two last figures are the entry.

<i>Analogue Inputs Agrónic 2500 and Agrónic 5500</i>			
4 00 00			Description
Protocol	Device	Sensor	
4: SDI-12	01 – 08	01 - 24	The input values depend on the type of the device.

When an input or output of an SDI-12 device is assigned to any of the Agrónic 4500 parameters, the first digit is always '120'; the next three digits indicate the device number, and the last two digits indicate the input.

<i>Analogue Inputs for Agrónic 4500</i>			
120 000 00			Description
Protocol	Device	Sensor	
120: SDI-12	01 – 08	01 - 24	The input values depend on the type of the device.

2. Consultation

2.1. COMMUNICATION CONSULT ON THE CONTROLLERS

To view the SDI-12 readings on Agrónic devices, you must access the query menu corresponding to the model.

On the Agrónic 2500, this is accessed via **'Consult - Communications - SDI-12'**, while on the Agrónic 4500 it is accessed via **'Consult - Devices - F2 (SDI-12)'**. In both cases, there is a query screen for each device.

From a module's query screen, it is possible to view the values of the device's inputs using the corresponding keys: on the Agrónic 2500, press **'1'**, and on the Agrónic 4500, press **'F3'** and **'F4'**. The screen displays the device identifier and the readings it provides, with three decimal places. If the device is an Aquacheck, the humidity and temperature of the first level are shown.

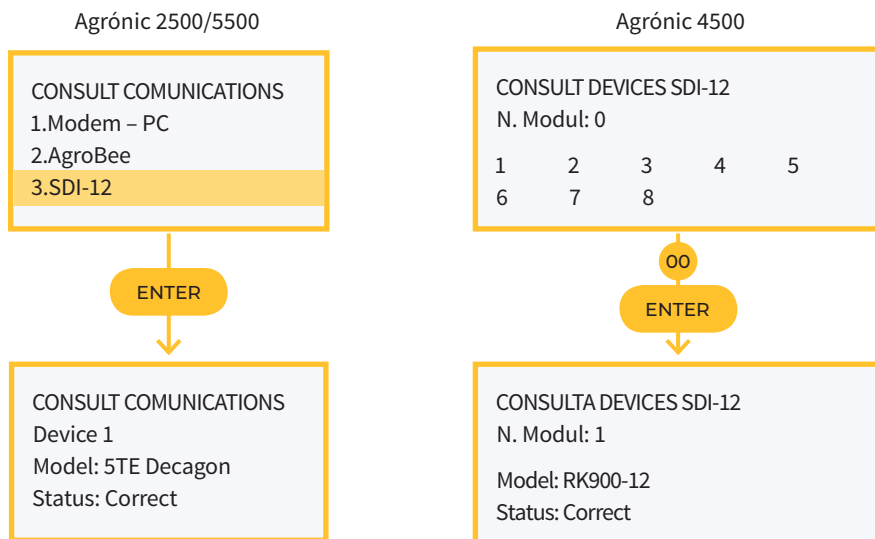



Model: 5TE Decagon	Model that has been configured
State: No communication	There is no communication with the device.
State: Correct	The device is communicating correctly. The rest of the consultations only show them if the module status is correct.
State: Error	Communication with the device has been lost.
Model error	The model configured in the Agrónic does not correspond to that of the device.
Version: 4.02	Device software version.







3. Connecting

For box-type devices, connect the two connectors on the right side of the controller.

For build-in format devices, a shielded cable must be used.

In both cases, installation next to other voltage cables and an inverter should always be avoided.

SDI12 BUS	Box-type cable colours
Common, 0V	 Brown
Multi-sensor power, +12V	 Blue
Multi-sensor digital output	 Yellow/Green

4 ANALOGUE INPUTS	Box-type cable colours
Common, 0V	 White
Sensor power supply, +12V	 Brown
Sensor A2-1	 Green
Sensor A2-2	 Yellow
Sensor A2-3	 Grey
Sensor A2-4	 Pink



IMPORTANT

The SDI-12 bus cable must be shielded and should not run near cables carrying alternating current.

The flush-mounted devices, the connections are located on the rear side. Follow the wiring instructions shown in the image and table below.

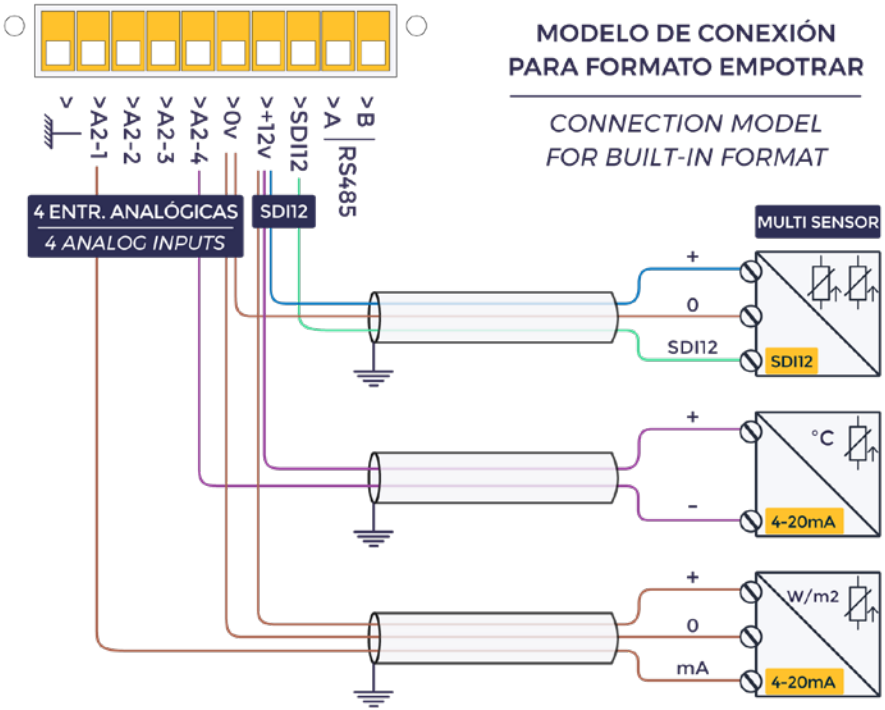

**MODELO DE CONEXIÓN
PARA FORMATO EMPOTRAR**



**CONNECTION MODEL
FOR BUILT-IN FORMAT**

SDI12 BUS	Build-in format terminals
Common, 0V	0V
Multi-sensor power, +12V	+12V
Multi-sensor digital output	SDI12

4 ANALOGUE INPUTS	Build-in format terminals
Common, 0V	0V
Sensor power supply, +12V	+12V
Sensor A2-1	A2-1
Sensor A2-2	A2-2
Sensor A2-3	A2-3
Sensor A2-4	A2-4

3.1. WIRING ON AGRÓNIC 4500

For both box-mounted and flush-mounted models, the cable connector must be connected to the terminals labeled SDI-12. In both cases, installations near other power cables or a variable frequency drive should be avoided.

BUS SDI12	Cables colour	Function
Common	 Brown	0 V
Multisensor power supply	 Blue	+12 V
Multisensor digital output	 Yellow / Blue	SDI12

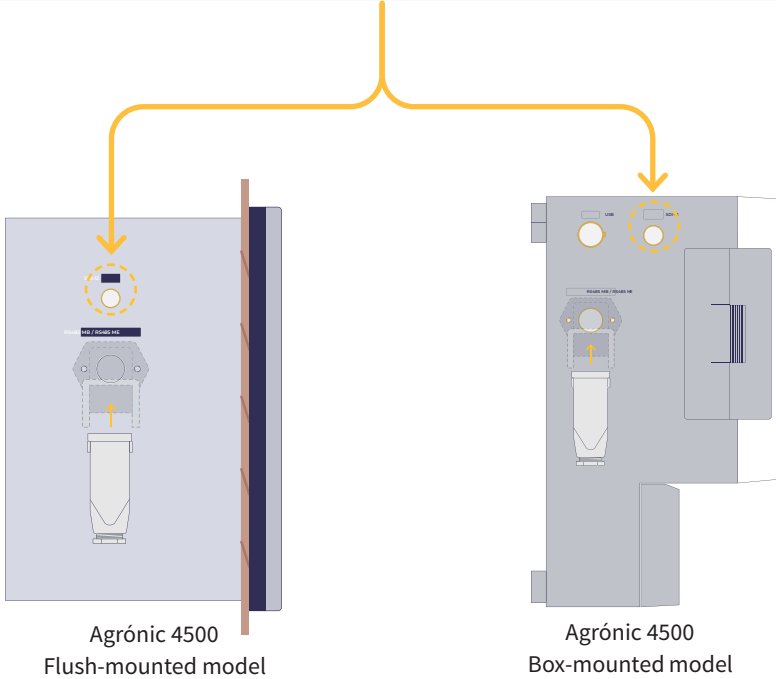

Sistemes Electrònics Progrés, S.A.

Polígon Industrial, C/ from la Coma, 2 | 25243 El Palau d'Anglesola | Lleida | España

Tel. +34 973 32 04 29 | info@progres.es | www.progres.es

R-2246-2